

APRIL. 1998

DATA SHEET

KA2141



R/G/B VIDEO AMPLIFIER

The KA2141 is a very high frequency Video amplifier system to be used in Monitor. It contains 3 matched R/G/B video amplifiers with blank signal and clamp gate pulse and provides a flexible interfacing to DC controlled adjustment system

FUNCTIONS

- R/G/B Video Amplifier
- Contrast/SUB contrast control
- Brightness control
- Blank gate/Clamp gate
- Video clamp

FEATURES

- 3 - channel R/G/B Video Amplifier: 85MHz bandwidth.
- DC contrast control range: -38dB (0V ~ 4V)
- DC sub contrast control range: -11dB (0V ~ 4V)
- Maximum Video output level: 7Vpp
- DC Brightness control range: 0V ~ 4V
- Include blank gate and clamp gate signal processing block

20-DIP-300A

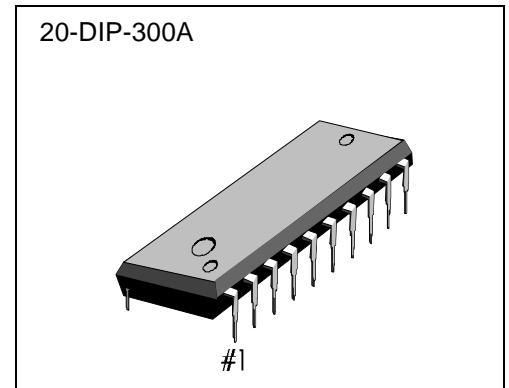

ORDERING INFORMATION

Device	Package	Operating Temperature
KA2141	20-DIP-300	-25 °C ~ +70 °C

BLOCK DIAGRAM

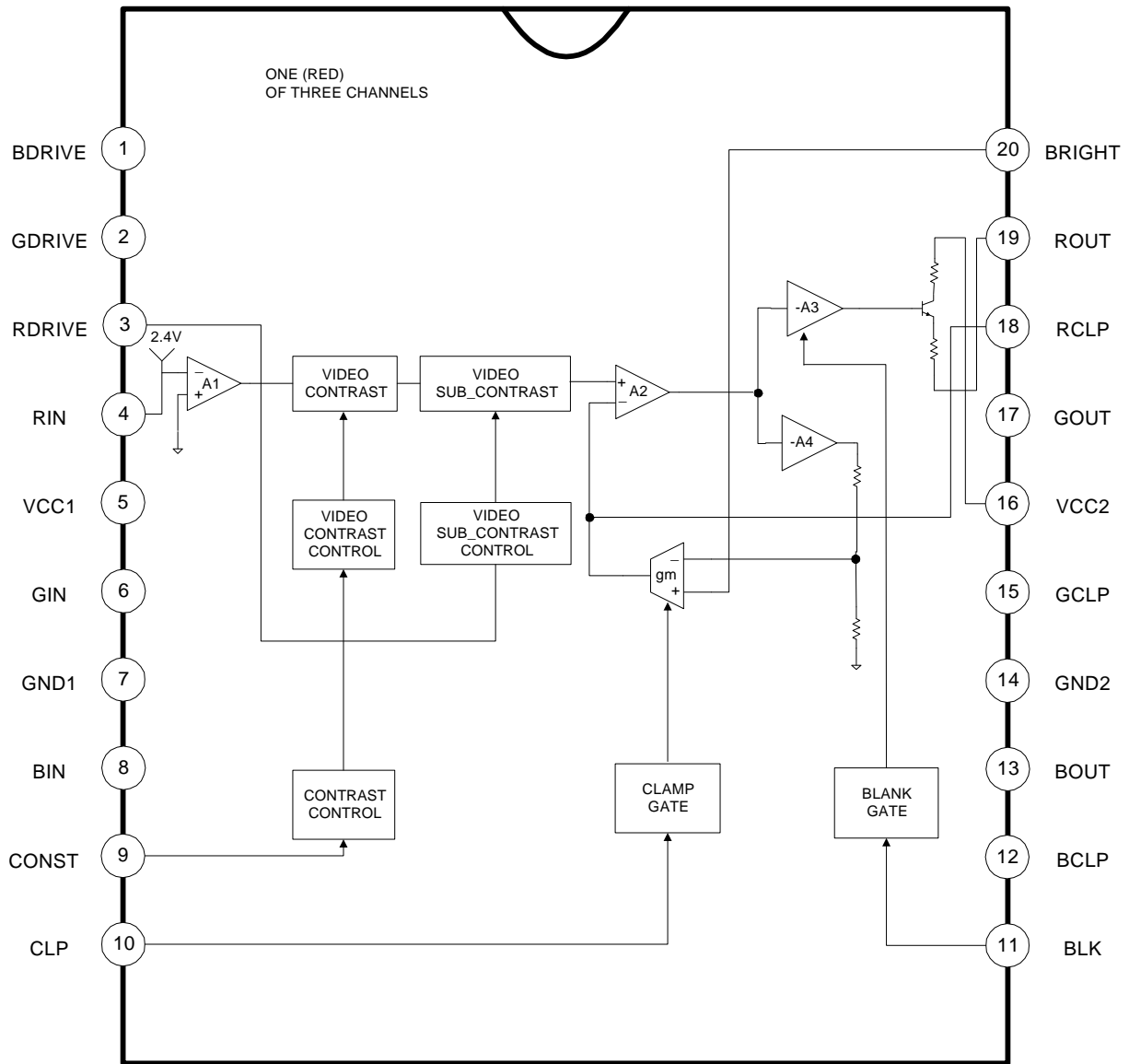

PIN CONFIGURATIONS

Table 1. Pin Configurations

Pin No	Symbol	I/O	Configurations
1	BDRIVE	I	Blue Gain Control
2	GDRIVE	I	Green Gain Control
3	RDRIVE	I	Red Gain Control
4	RIN	I	Red Video Input
5	V _{CC1}	-	V _{CC1} = 12V
6	GIN	I	Green Video Input
7	GND1	-	Ground1
8	BIN	I	Blue Video Input
9	CONST	I	Contrast Control Input
10	CLP	I	Clamp Gate Pulse Input
11	BLK	I	Blank Gate Pulse Input
12	BCLP	-	Blue Clamp Capacitor
13	BOUT	O	Blue Video Output
14	GND2	-	Ground2
15	GCLP	-	Green Clamp Capacitor
16	V _{CC2}	-	V _{CC2} = 12V
17	GOUT	O	Green Video Output
18	RCLP	-	Red Clamp Capacitor
19	ROUT	O	Red Video Output
20	BRIGHT	I	Brightness Control Input

PIN DESCRIPTION

Table 2. Pin Description

Pin No	Pin Name	Schematic	Description
4 6 8	Red Video Input (RIN) Green Video input (GIN) Blue Video Input (BIN)		Max input video signal is 0.7Vpp
9 1 2 3	Video Contrast (CONST) Blue Drive (BDRIVE) Green Drive (GDRIVE) Red Drive (RDRIVE)		Video maximum contrast control range (0V ~ 4V) is -38dB Sub contrast control range (0V ~ 4V) is -11dB
5 17	V _{CC1} V _{CC2}	-	Supply voltage
7 14	GND1 GND2	-	Ground
10	Clamp Gate Input (CLP)		Video amp actives when clamp gate signal is in low TTL level

Table 2. Pin Description(Continued)

Pin No	Pin Name	Schematic	Description
11	Blank Gate Input (BLK)		Video amp activates when blank gate signal is in low TTL level
18 16 13	Red Video output (ROUT) Green Video output (GOUT) Blue Video output (BOUT)		Video signal output
12 15 19	Blue Clamp Cap (BCLP) Green Clamp Cap (GCLP) Red Clamp Cap (RCLP)		Brightness controlling active by charging and discharging of the external cap (0.1uF)
20	Bright Control (BRIGHT)		During the clamp gate period, video signal's DC level (clamp level) is fixed according to the brightness control voltage

ABSOLUTE MAXIMUM RATINGS (TA = 25 °C)**Table 3. Absolute Maximum Ratings**

No	Item	Symbol	Value			Unit
			Min	Typ	Max	
1	Maximum Supply Voltage	Vccmax	-	-	13.5	V
2	Operating Temperature	Topr	-25	-	70	°C
3	Storage Temperature	Tstg	-65	-	150	°C
4	Maximum Power Dissipation	Pdmax	-	-	1.7	W
5	Thermal Resistance (Junction-ambient)	θ_{ja}	-	71	-	°C/W
6	Junction Temperature	Tj	-	150	-	°C

ELECTRICAL CHARACTERISTICS

DC Electrical Characteristics: T_{amb} = 25 °C, V_{CC} = 12V

Table 4. DC Electrical Characteristics

Parameter	Symbol	Conditions	Min	Typ	Max	Unit
Supply Current	I _{CC}	V4.6.8=none, V12.15.18=none V1.2.3.9.11=4V, V10=0V, V20=1V	60	80	100	mA
Max. Supply Current	I _{CCmax}	Same conditions of I _{ca} except V _{ic} =12.6V	75	95	115	mA
R Input Bias Voltage	V _{Rb}	Same conditions of I _{ca} V _{cc} =12V	2.0	2.4	2.8	V
G Input Bias Voltage	V _{Gb}	Same conditions of I _{cc} V _{cc} =12V	2.0	2.4	2.8	V
B Input Bias Voltage	V _{Bb}	Same conditions of I _{cc} V _{cc} =12V	2.0	2.4	2.8	V
R Clamp Gate Low Input Voltage	V _{10LR}	V4.6.8.12.15.18=none V1.2.3.9.11=4V, V20=1V V10=variable	0.8	1.5	3.0	V
G Clamp Gate Low Input Voltage	V _{10LG}	V4.6.8.12.15.18=none V1.2.3.9.11=4V, V20=1V V10=variable	0.8	1.5	3.0	V
B Clamp Gate Low Input Voltage	V _{10LB}	V4.6.8.12.15.18=none V1.2.3.9.11=4V, V20=1V V10=variable	0.8	1.5	3.0	V

Table 4. DC Electrical Characteristics(Continued)

Parameter	Symbol	Conditions	Min	Typ	Max	Unit
R Clamp Gate High Input Voltage	V_{10HR}	V4.6.8.12.15.18=none V1.2.3.9.11=4V, V20=1V V10=variable	0.8	1.5	3.0	V
G Clamp Gate High Input Voltage	V_{10HG}	V4.6.8.12.15.18=none V1.2.3.9.11=4V, V20=1V V10=variable	0.8	1.5	3.0	V
B Clamp Gate High Input Voltage	V_{10HB}	V4.6.8.12.15.18=none V1.2.3.9.11=4V, V20=1V V10=variable	0.8	1.5	3.0	V
Clamp Gate Low Input Current	I_{10L}	V4.6.8.12.15.18=none V1.2.3.9.11=4V, V20=1V, V10=0V	-0.5	-0.2	-	μ A
Clamp Gate Low Input Current	I_{10H}	V4.6.8.12.15.18=none V1.2.3.9.11=4V, V20=1V, V10=12V	-	0.01	1.0	μ A
R Clamp-Cap Charge Current	$I_{clampR+}$	V4.6.8=none, V12.15.18= variable V1.2.3.9.11=4V, V10=0V, V20=4V	0.45	0.75	1.05	mA
G Clamp-Cap Charge Current	$I_{clampG+}$	V4.6.8=none, V12.15.18= variable V1.2.3.9.11=4V, V10=0V, V20=4V	0.45	0.75	1.05	mA
B Clamp-Cap Charge Current	$I_{clampB+}$	V4.6.8=none, V12.15.18= variable V1.2.3.9.11=4V, V10=0V, V20=4V	0.45	0.75	1.05	mA
R Clamp-Cap Discharge Current	$I_{clampR-}$	V4.6.8=none, V12.15.18= variable V1.2.3.9.11=4V, V10=0V, V20=0V	-1.05	-0.75	-0.45	mA
G Clamp-Cap Discharge Current	$I_{clampG-}$	V4.6.8=none, V12.15.18= variable V1.2.3.9.11=4V, V10=0V, V20=0V	-1.05	-0.75	-0.45	mA
B Clamp-Cap Discharge Current	$I_{clampB-}$	V4.6.8=none, V12.15.18= variable V1.2.3.9.11=4V, V10=0V, V20=0V	-1.05	-0.75	-0.45	mA
R Blank Gate Low Input Voltage	V_{11LR}	V4.5.8.12.15.18=none, V10=0V V1.2.3.9=4V, V20=1V, V11=variable	0.8	1.5	3.0	V

Table 4. DC Electrical Characteristics(Continued)

Parameter	Symbol	Conditions	Min	Typ	Max	Unit
G Blank Gate Low Input Voltage	V _{11LG}	V4.5.8.12.15.18=none, V10=0V V1.2.3.9=4V, V20=1V, V11 (2V → 0V)	0.8	1.5	3.0	V
B Blank Gate Low Input Voltage	V _{11LB}	V4.5.8.12.15.18=none, V10=0V V1.2.3.9=4V, V20=1V, V11 (2V → 0V)	0.8	1.5	3.0	V
R Blank Gate High Input Voltage	V _{11HR}	V4.5.8.12.15.18=none, V10=0V V1.2.3.9=4V, V20=1V, V11 (0V → 2V)	0.8	1.5	2.0	V
G Blank Gate High Input Voltage	V _{11HG}	V4.5.8.12.15.18=none, V10=0V V1.2.3.9=4V, V20=1V, V11 (0V → 2V)	0.8	1.5	2.0	V
B Blank Gate High Input Voltage	V _{11HB}	V4.5.8.12.15.18=none, V10=0V V1.2.3.9=4V, V20=1V, V11 (0V → 2V)	0.8	1.5	2.0	V
Blank Gate Low Input Current	I _{11L}	V4.5.8.12.15.18=none, V10=0V V1.2.3.9=4V, V20=1V, V11=0V	-5.0	-2.0	-	uA
Blank Gate High Input Current	I _{11RL}	V4.6.8=none, V12.15.18= variable V1.2.3.9.11=4V, V10=0V, V20=0V	-	-0.01	1.0	uA
R Output Low Voltage	V _{ORL}	V4.6.8=none, V12.15.18= variable V1.2.3.9.11=4V, V10=0V, V20=0V	-	0.1	0.2	V
G Output Low Voltage	V _{OCTL}	V4.6.8=none, V12.15.18= variable V1.2.3.9.11=4V, V10=0V, V20=0V	-	0.1	0.2	V
B Output Low Voltage	V _{OBL}	V4.5.8.12.15.18=none, V10=0V V1.2.3.9=4V, V20=1V, V11=variable	-	0.1	0.2	V
R Output High Voltage	V _{ORH}	V4.5.8.12.15.18=none, V10=0V V1.2.3.9=4V, V20=1V, V11 (2V → 0V)	6.2	7.0	8.3	V
G Output High Voltage	V _{OGH}	V4.5.8.12.15.18=none, V10=0V V1.2.3.9=4V, V20=1V, V11 (2V → 0V)	6.2	7.0	8.3	V
B Output High Voltage	V _{OBRL}	V4.5.8.12.15.18=none, V10=0V V1.2.3.9=4V, V20=1V, V11 (0V → 2V)	6.2	7.0	8.3	V
R Black Level Output Voltage	V _{ORBL}	V4.5.8.12.15.18=none, V10=0V V1.2.3.9=4V, V20=1V, V11 (0V → 2V)	0.7	1.0	1.3	V

Table 4. DC Electrical Characteristics(Continued)

Parameter	Symbol	Conditions	Min	Typ	Max	Unit
G Black Level Output Voltage	B_{OGBL}	V4.5.8.12.15.18=none, V10=0V V1.2.3.9=4V, V20=1V, V11 (0V → 2V)	0.7	1.0	1.3	V
B Black Level Output Voltage	V_{OBBL}	V4.5.8.12.15.18=none, V10=0V V1.2.3.9=4V, V20=1V, V11=0V	0.7	1.0	1.3	V
R-G Black Level Output Voltage	$\Delta R\text{-GBL}$	V4.5.8.12.15.18=none, V10=0V V1.2.3.9=4V, V20=1V, V11=12V	-0.3	-	0.3	V
G-B Black Level Output Voltage	$\Delta R\text{-BBL}$	V4.5.8.12.15.18=none, V10=0V V1.2.3.9=4V, V11=12V, V20=0V	-0.3	-	0.3	V
B-R Black Level Output Voltage	$\Delta R\text{-RBL}$	V4.5.8.12.15.18=none, V10=0V V1.2.3.9=4V, V11=12V, V20=0V	-0.3	-	0.3	V
R Blank Output Voltage	V_{ORB}	V4.5.8.12.15.18=none, V10=0V V1.2.3.9=4V, V11=12V, V20=0V	-	0.05	0.5	V
G Blank Output Voltage	B_{OGB}	V4.5.8.12.15.18=none, V10=0V V1.2.3.9=4V, V11=12V, V20=10V	-	0.05	0.5	V
B Blank Output Voltage	V_{OBB}	V4.5.8.12.15.18=none, V10=0V V1.2.3.9=4V, V11=12V, V20=10V	-	0.05	0.5	V
R Sub Drive Ctrl Input Current	I_{Rd}	V4.5.8.12.15.18=none, V10=0V V1.2.3=0/4V, V9=4V, V11=4V, V20=1V	-	0.25	2.0	μA
G Sub Drive Ctrl Input Current	I_{Gd}	V4.5.8.12.15.18=none, V10=0V V1.2.3=0/4V, V9=4V, V11=4V, V20=1V	-	0.25	2.0	μA
B Sub Drive Ctrl Input Current	I_{Bd}	V4.5.8.12.15.18=none, V10=0V V1.2.3=0/4V, V9=4V, V11=4V, V20=1V	-	0.25	2.0	μA
Contrast Control Input Current	I_{CON}	V4.5.8.12.15.18=none, V10=0V V1.2.3=4V, V9.20=0V, V11=4V	-	0.25	2.0	μA
Brightness Control Input Current	I_{brt}	V4.5.8.12.15.18=none, V10=0V V1.2.3=4V, V9.20=4V, V11=4V	-	1.0	2.0	μA
R Spot Killer Voltage	V_{spotR}	V4.5.8.12.15.18=none, V10=0V V1.2.3=4V, V9.20=4V, V11=4V	8.0	10.0	11.2	V
G Spot Killer Voltage	V_{spotG}	V4.5.8.12.15.18=none, V10=0V V1.2.3=4V, V9.20=4V, V11=4V	8.0	10.0	11.2	V
B Spot Killer Voltage	V_{spotB}	V4.5.8.12.15.18=none, V10=0V V1.2.3=4V, V9.20=4V, V11=4V	8.0	10.0	11.2	V

AC Electrical Characteristics: $T_{amb} = 25\text{ }^{\circ}\text{C}$, $V_{CC} = 12\text{V}$

Table 5. AC Electrical Characteristics

Parameter	Symbol	Conditions	Min	Typ	Max	Unit
R Video Amp Gain	AvmaxR	V1.2.3.9.11=4V, V12.15.18=none, V4.6.8=S1, V10=S8, V20=1/3V	15.5	17.5	19.5	dB
G Video Amp Gain	AvmaxG	V1.2.3.9.11=4V, V12.15.18=none, V4.6.8=S1, V10=S8, V20=1/3V	15.5	17.5	19.5	dB
B Video Amp Gain	AvmaxB	V1.2.3.9.11 = 4V, V12.15.18=none, V4.6.8=S1, V10=S8, V20=1/3V	15.5	17.5	19.5	dB
R-G Amp Gain Difference	AvR-G	V1.2.3.9.11=4V, V12.15.18=none, V4.6.8=S1, V10=S8, V20=1V	-1.0	-	1.0	dB
G-B Amp Gain Difference	AvG-B	V1.2.3.9.11=4V, V12.15.18=none, V4.6.8=S1, V10=S8, V20=1V	-1.0	-	1.0	dB
B-R Amp Gain Difference	AvB-R	V1.2.3.9.11=4V, V12.15.18=none, V4.6.8=S1, V10=S8, V20=1V	-1.0	-	1.0	dB
R Sub Dr. Ctrl Gain Difference1	AvDR1	V1.2.3=2V, V9.11=4V, V12.15.18=none, V4.6.8=S1, V10=S8, V20=1V	-6.0	-4.0	-2.0	dB
G Sub Dr. Ctrl Gain Difference1	AvDG1	V1.2.3=2V, V9.11=4V, V12.15.18=none, V4.6.8=S1, V10=S8, V20=1V	-6.0	-4.0	-2.0	dB
B Sub Dr. Ctrl Gain Difference1	AvDB1	V1.2.3=2V, V9.11=4V, V12.15.18=none, V4.6.8=S1, V10=S8, V20=1V	-6.0	-4.0	-2.0	dB
R Sub Dr. Ctrl Gain Difference2	AvDR2	V1.2.3=0.25V, V9.11=4V, V12.15.18=none, V4.6.8=S1, V10=S8, V20=1V	-13.0	-10.0	-7.0	dB
G Sub Dr. Ctrl Gain Difference2	AvDG2	V1.2.3=0.25V, V9.11=4V, V12.15.18=none, V4.6.8=S1, V10=S8, V20=1V	-13.0	-10.0	-7.0	dB
B Sub Dr. Ctrl Gain Difference	AvDB2	V1.2.3=0.25V, V9.11=4V, V12.15.18=none, V4.6.8=S1, V10=S8, V20=1V	-13.0	-10.0	-7.0	dB
R Contrast Ctrl Gain Difference1	AvCR1	V1.2.3=4V, V9=2V, V11=4V, V12.15.18=none, V4.6.8=S1, V10=S8, V20=1V	-8.0	-6.0	-4.0	dB
G Contrast Ctrl Gain Difference	AvCG1	V1.2.3=4V, V9=2V, V11=4V, V12.15.18=none, V4.6.8=S1, V10=S8, V20=1V	-8.0	-6.0	-4.0	dB
B Contrast Ctrl Gain Difference	AvCB1	V1.2.3=4V, V9=2V, V11=4V, V12.15.18=none, V4.6.8=S1, V10=S8, V20=1V	-8.0	-6.0	-4.0	dB

Table 5. AC Electrical Characteristics(Continued)

Parameter	Symbol	Conditions	Min	Typ	Max	Unit
R-G Amp Gain Difference	$\Delta AvR-G$	V1.2.3=4V, V9=4/2V, V11=4V, V12.15.18=none, V4.6.8=S1, V10=S8, V20=1V	-1.0	-	1.0	dB
G-B Amp Gain Difference	$\Delta AvR-B$	V1.2.3=4V, V9=4/2V, V11=4V, V12.15.18=none, V4.6.8=S1, V10=S8, V20=1V	-1.0	-	1.0	dB
B-R Amp Gain Difference	$\Delta AvR-R$	V1.2.3=4V, V9=4/2V, V11=4V, V12.15.18=none, V4.6.8=S1, V10=S8, V20=1V	-1.0	-	1.0	dB
R Contrast Ctrl Gain Difference ²	$AvCR2$	V1.2.3=4V, V9=0.25V, V11=4V, V12.15.18=none, V4.6.8=S1, V10=S8, V20=1V	-	-38.0	-30.0	dB
G Contrast Ctrl Gain Difference ²	$AvCG2$	V1.2.3=4V, V9=0.25V, V11=4V, V12.15.18=none, V4.6.8=S1, V10=S8, V20=1V	-	-38.0	-30.0	dB
B Contrast Ctrl Gain Difference ²	$AvCB2$	V1.2.3=4V, V9=0.25V, V11=4V, V12.15.18=none, V4.6.8=S1, V10=S8, V20=1V	-	-38.0	-30.0	dB
R Video Amp Bandwidth	$Rf-3dB$	V4.6.8=S2, V12.15.18=variable V10=4V, V20=1/3V	70	85	-	MHz
G Video Amp Bandwidth	$Gf-3dB$	V4.6.8=S2, V12.15.18=variable V10=4V, V20=1/3V	70	85	-	MHz
B Video Amp Bandwidth	$Bf-3dB$	V4.6.8=S2, V12.15.18=variable V10=4V, V20=1/3V	70	85	-	MHz
R Video Amp THD	R_{THD}	V4.5.8=S5, V12.15.18=none V1.2.3.10.11=4V, V9=Variable	-	1.0	5.0	%
G Video Amp THD	G_{THD}	V4.5.8=S5, V12.15.18=none V1.2.3.10.11=4V, V9=Variable	-	1.0	5.0	%
B Video Amp THD	B_{THD}	V4.5.8=S5, V12.15.18=none V1.2.3.10.11=4V, V9=Variable	-	1.0	5.0	%
R Video Amp IS01-10K	$R_{ISO1-10K}$	V4=S3, V6.8=none, V20=1V V12.15.18=variable V1.2.3.9.10.11=4V	-	-65	-45	dB
R Video Amp IS02-10K	$R_{ISO2-10K}$	V4=S3, V6.8=none, V20=1V V12.15.18=variable, V1.2.3.9.10.11=4V	-	-65	-45	dB
G Video Amp IS01-10K	$G_{ISO1-10K}$	V4.8=none, V6=S3, V20=1V V12.15.18=variable, V1.2.3.9.10.11=4V	-	-65	-45	dB
G Video Amp IS02-10K	$G_{ISO2-10K}$	V4.8=none, V6=S3, V20=1V V12.15.18=variable, V1.2.3.9.10.11=4V	-	-65	-45	dB

Table 5. AC Electrical Characteristics(Continued)

Parameter	Symbol	Conditions	Min	Typ	Max	Unit
B Video Amp IS01-10K	B _{ISO1-10K}	V4.6=none, V8=S3, V20=1V V12.15.18=variable, V1.2.3.9.10.11=4V	-	-65	-45	dB
B Video Amp IS02-10K	B _{ISO2-10K}	V4.6=none, V8=S3, V20=1V V12.15.18=variable, V1.2.3.9.10.11=4V	-	-65	-45	dB
R Video Amp IS01-10M	R _{ISO1-10M}	V6.8=none, V4=S3, V20=1V V12.15.18=variable, V1.2.3.9.10.11=4V	-	-50	-35	dB
R Video Amp IS02-10M	R _{ISO2-10M}	V6.8=none, V4=S3, V20=1V V12.15.18=variable, V1.2.3.9.10.11=4V	-	-50	-35	dB
G Video Amp IS01-10M	G _{ISO1-10M}	V6=S3, V4.8=none	-	-50	-35	dB
G Video Amp IS02-10M	G _{ISO2-10M}	V6=S3, V4.8=none	-	-50	-35	dB
B Video Amp IS01-10M	B _{ISO1-10M}	V8=S3, V4.6=none	-	-50	-35	dB
B Video Amp IS02-10M	B _{ISO2-10M}	V8=S3, V4.6=none	-	-50	-35	dB
R Video Rising Time	trR	V4.6.8=S6, V12.15.18=none V1.2.3.11=4V, V10=S8, V20=1V V9=variable	-	4.0	5.0	ns
G Video Rising Time	trG	V4.6.8=S6, V12.15.18=none V1.2.3.11=4V, V10=S8, V20=1V V9=variable	-	4.0	5.0	ns
B Video Rising Time	trB	V4.6.8=S6, V12.15.18=none V1.2.3.11=4V, V10=S8, V20=1V V9=variable	-	4.0	5.0	ns
R Video Falling Time	tfR	V4.6.8=S6, V12.15.18=none V1.2.3.11=4V, V10=S8, V20=1V V9=variable	-	4.0	5.0	ns
G Video Falling Time	tfG	V4.6.8=S6, V12.15.18=none V1.2.3.11=4V, V10=S8, V20=1V V9=variable	-	4.0	5.0	ns
B Video Falling Time	tfB	V4.6.8=S6, V12.15.18=none V1.2.3.11=4V, V10=S8, V20=1V V9=variable	-	4.0	5.0	ns
R Blank Output Rising Time	trBlankR	V4.6.8.12.15.18=none V1.2.3.9=4V, V11=S7, V10=0V V20=variable	-	6.0	15.0	ns

Table 5. AC Electrical Characteristics(Continued)

Parameter	Symbol	Conditions	Min	Typ	Max	Unit
G Blank Output Rising Time	trBlankG	V4.6.8.12.15.18=none V1.2.3.9=4V, V11=S7, V10=0V V20=variable	-	6.0	15.0	ns
B Blank Output Rising Time	trBlankB	V4.6.8.12.15.18=none V1.2.3.9=4V, V11=S7, V10=0V V20=variable	-	6.0	15.0	ns
R Blank Output Falling Time	tfBlankR	V4.6.8.12.15.18=none V1.2.3.9=4V, V11=S7, V10=0V V20=variable	-	7.0	20.0	ns
G Blank Output Falling Time	tfBlankG	V4.6.8.12.15.18=none V1.2.3.9=4V, V11=S7, V10=0V V20=variable	-	7.0	20.0	ns
B Blank Output Falling Time	tfBlankB	V4.6.8.12.15.18=none V1.2.3.9=4V, V11=S7, V10=0V V20=variable	-	7.0	20.0	ns

APPLICATION CIRCUIT

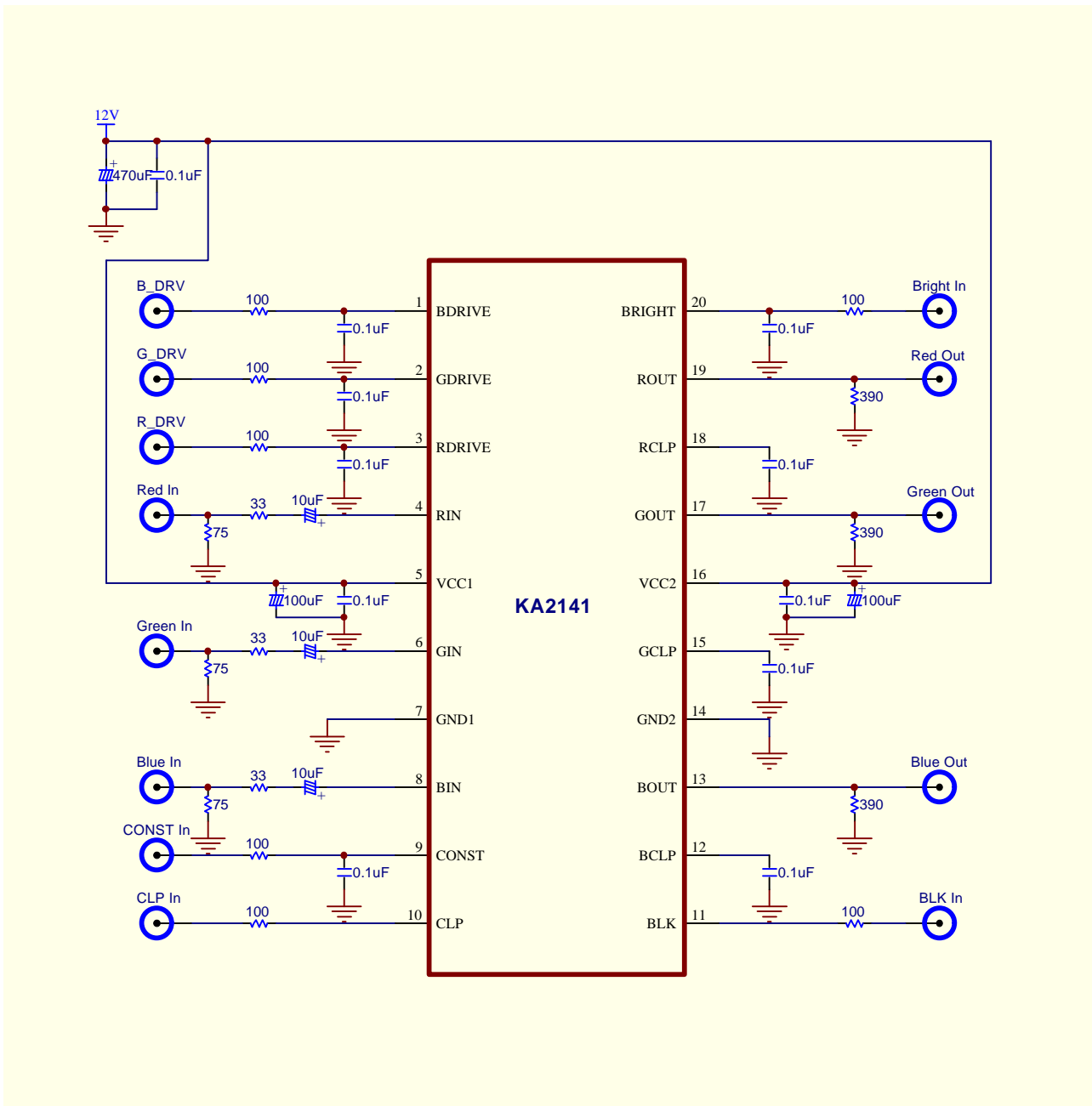

This datasheet has been download from:

www.datasheetcatalog.com

Datasheets for electronics components.