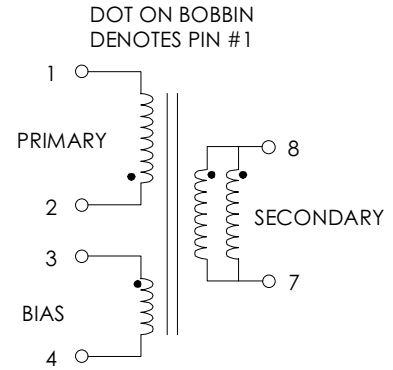

TABLE 1: ELECTRICAL SPECIFICATIONS AT 25 °C
 SWITCHING TRANSFORMER DESIGNED FOR USE WITH POWER INTEGRATIONS
 TOP224Y OR TOP202YA1. REFER TO APPLICATION CIRCUIT OF FIGURE 3.

PARAMETER	SPEC LIMITS			UNITS
	MIN.	TYP.	MAX.	
PRIMARY INDUCTANCE (2-1) VOLTAGE = 0.250Vrms FREQUENCY = 100 KHZ	630	700	770	μHY
TURNRATIO'S: SECONDARY (8-7) : PRIMARY (2-1) BIAS (3-4) : PRIMARY (2-1)	—	1:16.50 1: 6.60	—	± 3% ± 3%
PRI LEAKAGE IND. (7-8 SHORTED) VOLTAGE = 0.250Vrms FREQUENCY = 100 KHZ	—	30.0	40.0	μHY
HIPOT: PRIMARY TO SECONDARY BIAS TO SECONDARY	3000 3000	— —	— —	Vrms Vrms
APP CIRCUIT PARAMETERS: (1) AC LINE VOLTAGE 47/400 Hz OUTPUT VOLTAGE OUTPUT CURRENT CONTINUOUS (2) OUTPUT CURRENT PEAK LINE REGULATION (85 TO 265Vac) LOAD REGULATION 10-100% RIPPLE	85 — 0.0 — — — —	— 5.0 — — 0.20 0.20 50.0	265 — 3.0 4.0 — — —	Vac Vdc Amps Amps ±% ±% ±mV

FIGURE 1: SCHEMATIC DIAGRAM



NOTE1:
REINFORCED INSULATION SYSTEM, UL1950, IEC950, CSA-950:
 A) ALL MATERIALS MEET "UL", "CSA" & "IEC" REQUIREMENTS
 B) TRIPLE BASIC INSULATED SECONDARY.
 C) DESIGNED TO MEET ≥6.2mm CREEPAGE REQUIREMENTS.
 D) VARNISH FINISHED ASSEMBLY.
 E) UL 1950 & CSA-950 CERTIFIED: FILE #E162344.
 F) UL CLASS (B) 130 INSULATION SYSTEM PM130-R1, PM130-H1, PM130-H1A (UL FILE #E177139) OR ANY UL AUTHORIZED CLASS (B) INSULATION SYSTEM.

(1) REFER TO APPLICATION CIRCUIT OF FIGURE 3.
 (2) WITH RESISTOR "R6" IN CIRCUIT.

FIGURE 2: PHYSICAL DIMENSIONS mm (INCHES)

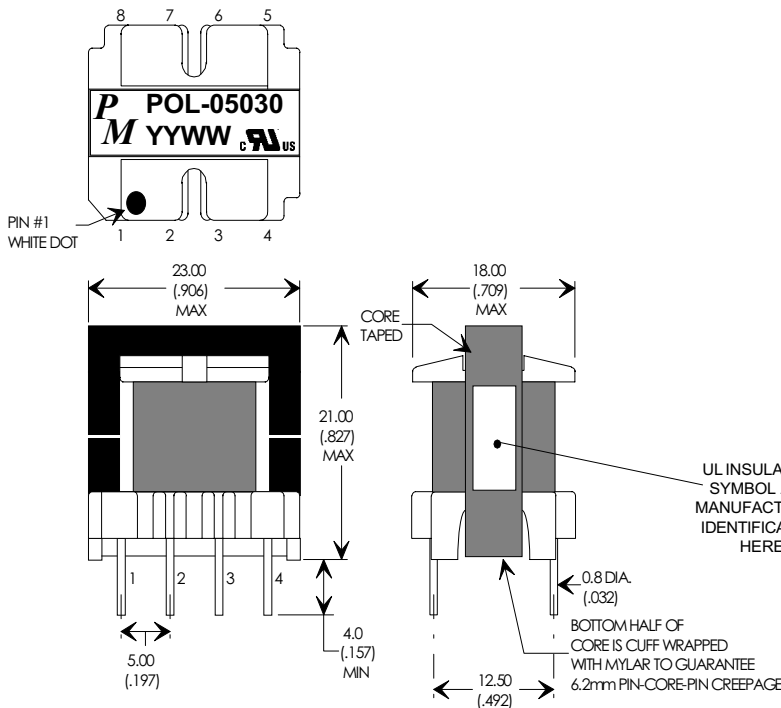

NOTE2:
 A) BOTTOM HALF OF CORE IS CUFF WRAPPED PRIOR TO ASSEMBLY. THIS GUARANTEES ≥6.2mm CREEPAGE PIN-CORE-PIN

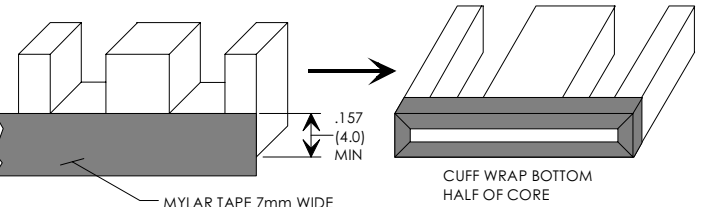

EI22/19/6, 8-PIN VERTICAL BOBBIN

REV.	DESCRIPTION OF CHANGES	BY
7/20/95	UPDATED TO SHOW CUFF TAPE.	TO
10/10/98	UPDATED TO ADD UL 1950 & CE-950 APPROVAL & MARKING	TO
04/15/99	UPDATED TO UL CLASS (B) 130 INSULATION SYSTEM	MD



UNLESS OTHERWISE SPECIFIED
 DIMENSIONS ARE IN MM
 DIMENSIONAL TOLERANCES ARE:
 DECIMALS ANGLES
 .X ± .25 ±0° 30'
 .XX ± .15
 DO NOT SCALE DRAWING

TRANSFORMER CONTROL DRAWING

PREMIER P/N: POL-05030	REVISION: 04/15/99
DRAWN BY: TOM O'NEIL	REF: TOP224Y
SCALE: NONE	SHEET: 1 OF 6

APPLICATION NOTES

Premier Magnetics' POL-05030 Switch Mode Transformer was designed for use with Power Integrations, Inc. TOP224Y three terminal off-line PWM switching regulator in the Flyback Buck-Boost circuit configuration. This conversion topology can provide isolated multiple outputs with efficiencies up to 90%. Premier's POL-05030 transformer has been optimized to provide maximum power throughput.

The TOPXXX series from Power Integrations, Inc. are self contained 100KHz three terminal voltage controlled PWM switching regulators. This series contains all necessary functions for an off-line switched mode control DC power source. These switching regulators provide a very simple solution to off-line designs. The inductors and transformer used with the PWR-TOPXXX are critical to the performance of the circuit. They define the overall efficiency, output power and overall physical size.

Below is a universal input high precision 15 watt application circuit utilizing Power Integrations PWR-TOP224Y OR TOP-202YA1 switching regulator in the flyback buck-boost configuration. The component values listed are intended for reference purposes only. Resistor R6 is required to prevent output runaway (loss of regulation) if the external load could be less than 100mA.

FIGURE 3: TYPICAL APPLICATION CIRCUIT

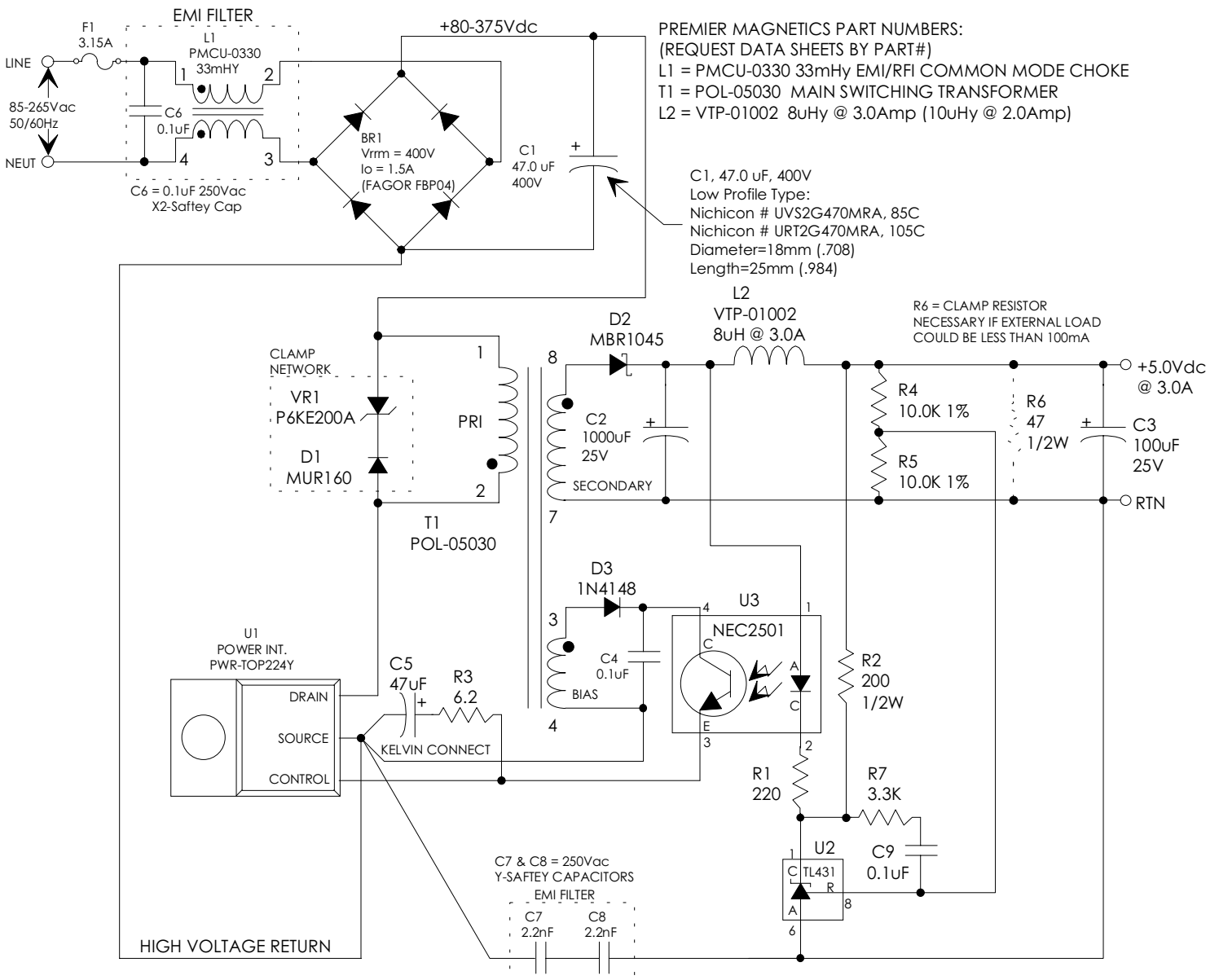

**Premier
Magnetics Inc.**

UNLESS OTHERWISE SPECIFIED
 DIMENSIONS ARE IN MM
 DIMENSIONAL TOLERANCES ARE:
 DECIMALS ANGLES
 .X ± .25 ±0° 30'
 .XX ± .15
 DO NOT SCALE DRAWING

TRANSFORMER CONTROL DRAWING

PREMIER P/N: POL-05030	REVISION: 04/15/99
DRAWN BY: TOM O'NEIL	REF: TOP224Y
SCALE: NONE	SHEET: 2 OF 6